



Making Your World
A Little Easier.™

Use And Care

G U I D E

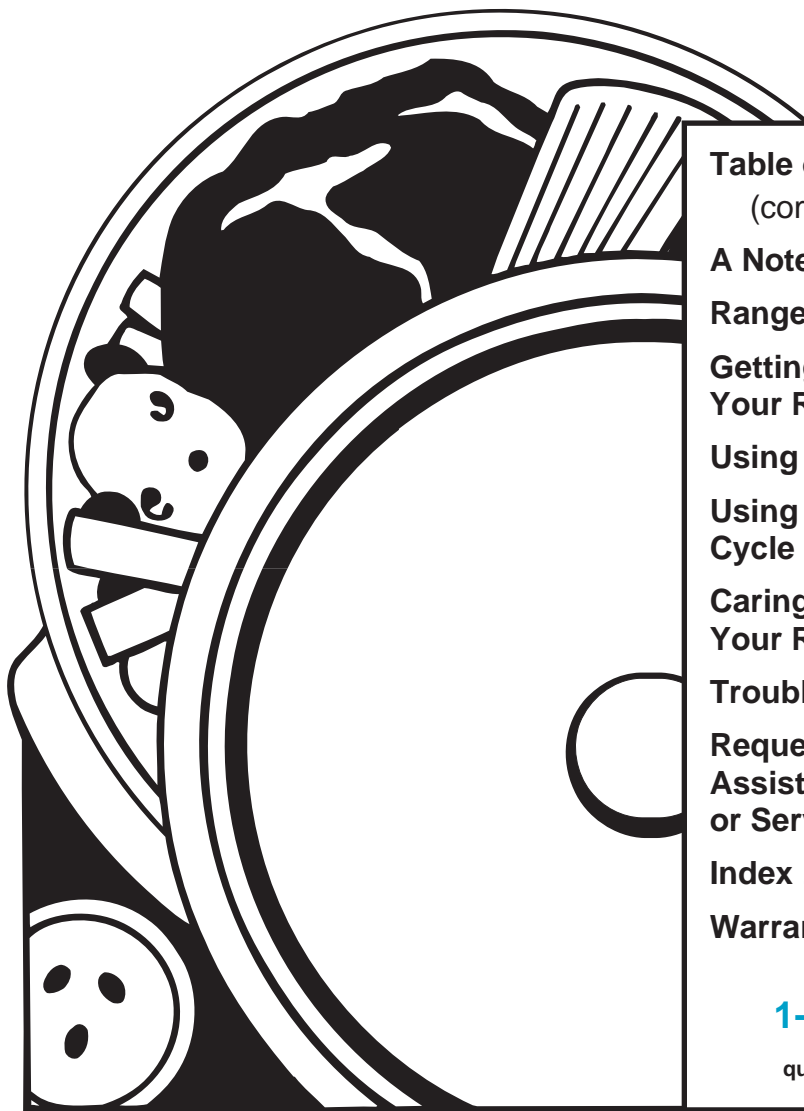

Table of Contents (complete)	2
A Note to You	3
Range Safety	4-7
Getting to Know Your Range	8
Using Your Range	9
Using the Self-Cleaning Cycle	38
Caring for Your Range	44
Troubleshooting	50
Requesting Assistance or Service	52
Index	54
Warranty	56

1-800-253-1301
Call us with
questions or comments.

SELF-CLEANING ELECTRIC DROP-IN RANGE

PART NO. 4450274

MODEL RS675PXE

Table of Contents

A Note to You	3	Energy saving tips	25
Range Safety	4-7	Using the electronic MEALTIMER™ control	26
Getting to Know Your Range	8	The oven vent	37
Using Your Range	9	Using the Self-Cleaning Cycle	38
Using the coil elements	9	Before you start	38
Positioning racks and pans	11	Before setting the controls	39
For best air circulation	12	Setting the controls	39
Using aluminum foil for baking	12	Special tips	43
The electronic oven control	13	How the cycle works	43
Starting a function	14	Caring for Your Range	44
Canceling a function	14	Cleaning chart	44
Setting the clock	15	Coil elements and reflector bowls	46
Using the electronic Minute Timer	16	Removing the oven door	48
Audible signals	17	The oven lights	49
Baking/roasting	18	Troubleshooting	50
Roasting tips	20	Requesting Assistance or Service	52
Adjusting the oven temperature control	20	Index	54
Broiling	22	Warranty	56
Broiling tips	25		

A Note to You

Thank you for buying a WHIRLPOOL® appliance.

Because your life is getting busier and more complicated, WHIRLPOOL appliances are easy to use, save time, and help you manage your home better. To ensure that you enjoy years of trouble-free operation, we developed this Use and Care Guide. It is full of valuable information about how to operate and maintain your appliance properly and safely. Please read it carefully.

Also, please complete and mail the **Product Registration Card** provided with your appliance. The card helps us notify you about any new information on your appliance.

Please record your model's information.

Whenever you call to request service for your appliance, you need to know your complete model number and serial number. You can find this information on the model and serial number plate (see diagram in the "Getting to Know" section).

Please also record the purchase date of your appliance and your dealer's name, address, and telephone number.

Model Number _____

Serial Number _____

Purchase Date _____

Dealer Name _____

Dealer Address _____

Dealer Phone _____

Keep this book and the sales slip together in a safe place for future reference.

**Our Consumer Assistance Center
number is toll-free.**

1-800-253-1301

Range Safety

Your safety and the safety of others is very important.

We have provided many important safety messages in this manual and on your appliance. Always read and obey all safety messages.



This is the safety alert symbol.

This symbol alerts you to hazards that can kill or hurt you and others.

All safety messages will be preceded by the safety alert symbol and the word "DANGER" or "WARNING." These words mean:

⚠ DANGER

You will be killed or seriously injured if you don't follow instructions.

⚠ WARNING

You can be killed or seriously injured if you don't follow instructions.

All safety messages will identify the hazard, tell you how to reduce the chance of injury, and tell you what can happen if the instructions are not followed.

IMPORTANT SAFETY INSTRUCTIONS

⚠ WARNING

To reduce the risk of fire, electrical shock, injury to persons, or damage when using the range, follow basic precautions, including the following:

General

- Read all instructions before using the range.
- Install or locate the range only in accordance with the provided Installation Instructions. The range must be installed by a qualified installer. The range must be properly connected to electrical supply and grounded.

installed anti-tip devices. To check if the devices are installed properly, open the oven door, remove a screw at the bottom of each side trim, remove the side trims, and verify that the anti-tip devices are engaged to cabinets with two screws through the mounting holes in the mounting rail of the oven.



WARNING: To reduce the risk of tipping of the appliance, the appliance must be secured by properly

- **CAUTION:** Do not store things children might want above the range. Children could be burned or injured while climbing on it.
- Do not leave children alone or unattended in area where the range is in use. They should never be allowed to sit or stand on any part of the range. They could be burned or injured.
- Do not operate the range if it is damaged or not working properly.
- Do not use the range for warming or heating the room. Persons could be burned or injured, or a fire could start.
- Use the range only for its intended use as described in this manual.



- Do not touch surface units, areas near units, heating elements, or interior surfaces of oven. Surface units and heating elements may be hot even though they are dark in color. Areas near surface units and interior surfaces of an oven

become hot enough to cause burns. During and after use, do not touch, or let clothing or other flammable materials contact surface units, areas near units, heating elements, or interior surfaces of oven until they have had sufficient time to cool. Other surfaces of the range, such as the oven vent opening, the surface near the vent opening, the cooktop, and the oven door and window, could also become hot enough to cause burns.



- Do not wear loose or hanging garments when using the range. They could ignite if they touch a hot surface unit and you could be burned.
- Use only dry pot holders. Moist or damp pot holders on hot surfaces could result in burns from steam. Do not let pot holder touch hot heating elements. Do not use a towel or bulky cloth for a pot holder. It could catch on fire.
- Keep range vents unobstructed.

continued on next page

RANGE SAFETY

- Do not heat unopened containers. They could explode. The hot contents could cause burns and container particles could cause injury.
- Use only cookware approved for oven use. Follow cookware manufacturer's instructions, especially when using glass or plastic cookware.
- Do not store flammable materials on or near the range. The fumes could create an explosion and/or fire hazard.
- Check to be sure glass cookware is safe for use on the range. Only certain types of glass, glass-ceramic, ceramic, earthenware, or other glazed cookware are suitable for cooktops without breaking due to the sudden change in temperature.
- Never leave surface units unattended at high heat settings. A boilover could result and cause smoking and greasy spillovers that could ignite.

When using the cooktop

- Make sure the reflector bowls are in place during cooking. Cooking without reflector bowls could subject the wiring and components underneath them to damage.
- Do not line reflector bowls with aluminum foil or other liners. Improper installation of these liners could result in a risk of electric shock or fire.
- Select a pan with a flat bottom that is about the same size as the surface unit. If pan is smaller than the surface unit, some of the heating element will be exposed and could result in the igniting of clothing or pot holders. Correct pan size also improves cooking efficiency.



- Turn pan handles inward, but not over other surface units. This will help reduce the chance of burns, igniting of flammable materials, and spills due to bumping of the pan.

When using the oven

- Always position oven rack(s) in desired location while oven is cool. If a rack must be removed while oven is hot, do not let pot holder contact hot heating element in oven.
- Use care when opening oven door. Let hot air or steam escape before removing or replacing food.

Grease

- Grease is flammable. Do not allow grease to collect around cooktop. Wipe spillovers immediately.



- Do not use water on grease fires. Never pick up a flaming pan. Smother flaming pan on range by covering with a well-fitted lid, cookie sheet, or flat tray. Flaming grease outside of pan can be extinguished with baking soda or, if available, a multipurpose dry chemical or foam-type extinguisher.

Care and cleaning

- Do not soak removable heating elements in water. The element will be damaged and shock or fire could result.
- Small amounts of formaldehyde and carbon monoxide are given off in the Self-Cleaning cycle from fiberglass insulation and food decomposition. Significant exposure to these substances could cause cancer or reproductive harm. Exposure can be minimized by venting with a hood or open window and wiping out excess food spills prior to self-cleaning.



- Do not use oven cleaners. No commercial oven cleaner or oven liner protective coating of any kind should be used in or around any part of the oven.
- Before self-cleaning the oven, remove broiler pan, broiler grid, oven racks, and other utensils. Do not use your oven to clean miscellaneous parts unless you are instructed to do so in this Use and Care Guide.
- Do not clean door gasket. It is essential for a good seal. Care should be taken not to rub, damage, or move the gasket. Clean only parts recommended in this Use and Care Guide.
- Do not repair or replace any part of the range unless specifically recommended in this manual. All other servicing should be referred to a qualified technician.
- Disconnect the electrical supply before servicing the range.

– SAVE THESE INSTRUCTIONS –

Getting to Know Your Range

This section tells you what features your range has and where they are located. Please review this information before using your range. To help you find information on specific parts or features quickly, page references are included.

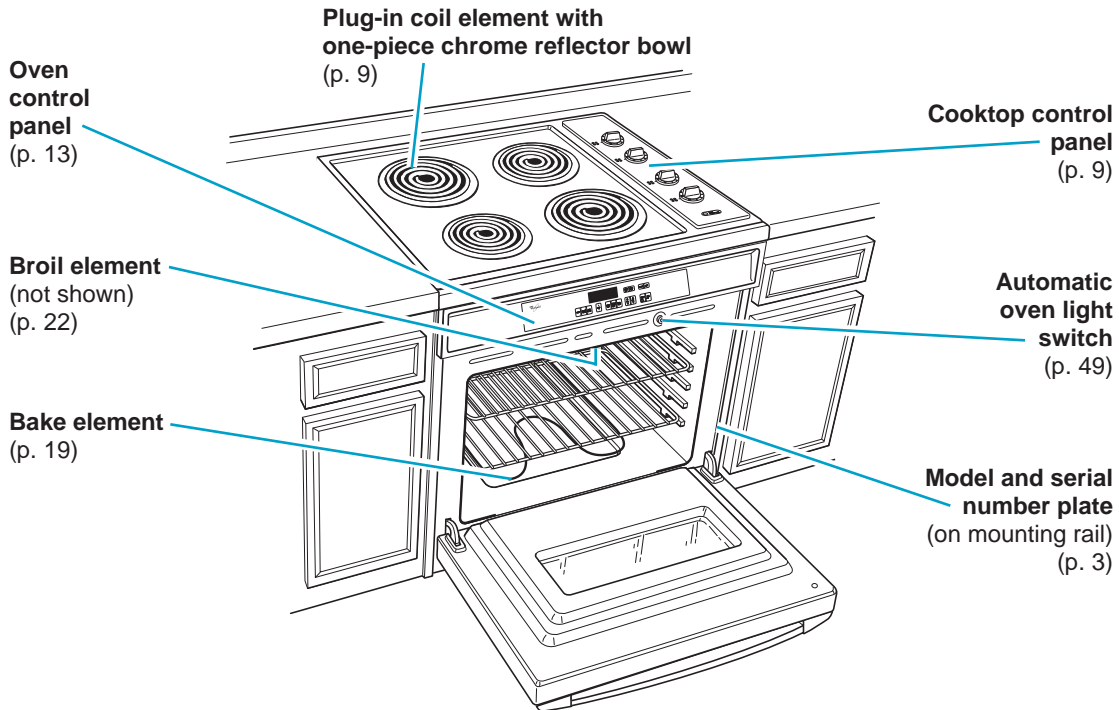

Cooktop control panel

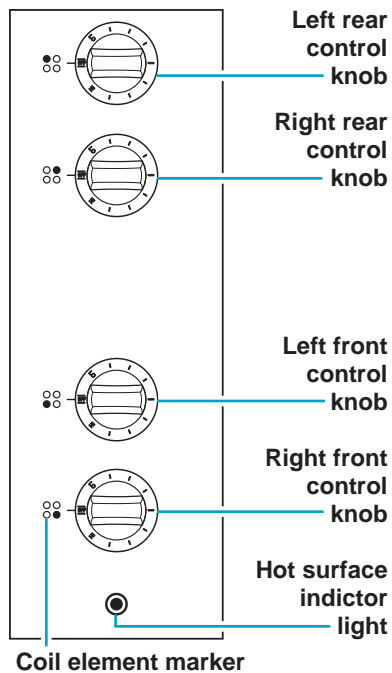

NOTE: Oven cooling fan remains on when oven is off until cavity temperature cools down.

Using Your Range

To get the best cooking results, you should use your range the correct way. This section tells you what you need to know to use your range safely and efficiently.

Using the coil elements

Push in control knobs before turning them to a setting. You can set them anywhere between HI and OFF.

Coil element markers

The solid dot in the coil element marker shows which coil element is turned on by that knob.

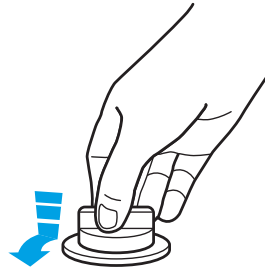

Hot surface indicator light

The Hot Surface Indicator Light on the cooktop surface will glow when any of the coil elements are turned on. The Indicator Light will continue to glow as long as the coil elements are too hot to touch, even after they are turned off.



⚠ WARNING



Fire Hazard

Turn off all controls when done cooking.

Failure to do so can result in death, fire, or burns.

Until you become familiar with the settings, use the chart at right as a guide. For best results, start cooking at the high setting; then turn the control knob down to continue cooking.

SETTING	RECOMMENDED USE
HI	<ul style="list-style-type: none">• To start foods cooking.• To bring liquids to a boil.
Medium-high	<ul style="list-style-type: none">• To hold a rapid boil.• To fry chicken or pancakes.
Medium (opposite OFF)	<ul style="list-style-type: none">• For gravy, pudding, and icing.• To cook large amounts of vegetables.
Medium-low	<ul style="list-style-type: none">• To keep food cooking after starting it on a higher setting.
LO	<ul style="list-style-type: none">• To keep food warm until ready to serve.

USING YOUR RANGE

Cookware tips

- **Use the correct cookware** to prevent damage to the coil elements, cooktop, wiring, and surrounding areas.
- **If the cookware is too small** for the coil element or the bottom is not flat, the coil element could stay glowing red for an extended length of time causing damage to the range.
- **If you start cooking on high**, it is important to turn the control down to a lower setting to complete cooking.
- **Flat-bottomed cookware**, including woks, canners, and teakettles, will provide better contact with the coil element and provide the best cooking results.
- **Warped, dented, and ribbed-bottomed cookware** can result in uneven cooking due to incomplete contact with the coil element.
- **Cookware** that has been designed with slightly indented bottoms or small expansion channels can be used.
- **Choose medium to heavy gauge** (thickness) cookware.
- **The pan material** (type of metal or glass) affects how quickly and evenly the pan heats.

NOTE: Do not leave empty cookware, or cookware which has boiled dry, on a hot coil element. The cookware could overheat causing damage to the cookware or coil element.

Home canning information

- **Use flat-bottomed** canners/pans for best results.

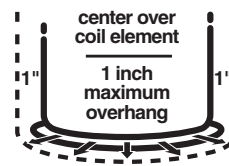

- **Use the largest coil element** for best results. Also, use a canner/pan that you can center over the coil element and that does not extend more than 1 inch outside the coil element area. Large diameter canners/pans, if not centered correctly, trap heat and can cause damage to the cooktop.
- **Do not place your canner** on 2 coil elements at the same time. Too much heat will build up and damage the cooktop.
- **Start with hot water.** This reduces the time the control is set on high. Reduce the heat setting to the lowest position needed to keep water boiling.
- **Keep reflector bowls clean** for best heat reflection.
- **When canning for long periods of time**, alternate use of the coil elements between batches to allow the coil elements to cool down, or prepare food in small batches.
- **Refer** to your canner manual for specific instructions.

Optional canning kit

The large diameter of most water-bath or pressure canners, combined with high heat settings for long periods of time, can shorten the life of regular coil elements and cause damage to the cooktop.

If you plan to use the cooktop for canning, we recommend the installation of a Canning Kit. Order the kit (Part No. 242905) from your Whirlpool dealer or authorized service company.

Positioning racks and pans

General guidelines

- **Before turning on the oven**, place oven racks where you need them.
- **To move rack(s)**, lift rack(s) at front and pull out.
- **Be sure** the rack(s) is level.
- **Use pot holders or oven mitts** to protect your hands, if rack(s) must be moved while the oven is hot.
- **For baking/roasting with 1 rack**, place the rack so the top of the food will be centered in the oven.
- **When baking/roasting on 2 racks**, position racks in oven to allow good circulation of air around all the food.

Bakeware tips

- **When baking with insulated cookie sheets or baking pans**, place them in the bottom third of the oven. You may need to increase the recommended baking times, so test for doneness before removing from the oven.
- **When using ovenproof glassware or dark bakeware**, reduce the oven temperature by 25°F, but use the same baking time. Because these pans absorb heat, producing darker bottom browning and crispier crusts, place the rack in the center of the oven. When baking pies and bread, you can use the temperature suggested in the recipe.

Rack placement for specific foods:

FOOD	RACK POSITION
Frozen pies, large roasts, turkeys, angel food cakes	Lowest level or 2nd level from bottom
Bundt cakes, most quick breads, yeast breads, casseroles, meats	2nd level from bottom
Cookies, biscuits, muffins, cakes, nonfrozen pies	2nd or 3rd level from bottom

NOTE: For recommended rack placement when broiling, see the “Broiling rack position chart.”

For best air circulation

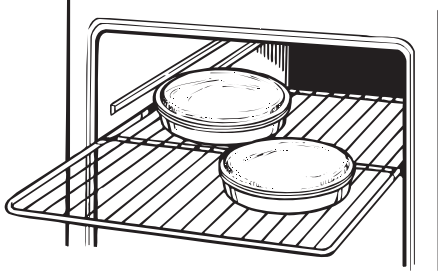

Hot air must circulate around the pans in the oven for even heat to reach all parts of the oven. This results in better baking.

- **Place** the pans so that one is not directly over the other.
- **For best results, allow** 1½ to 2 inches of space around each pan and between pans and oven walls.
- **Use** only one cookie sheet in the oven at a time.

Use the following as a guide to determine where to place the pans:

1 pan

Place in the center of the oven rack.

2 pans

Place in opposite corners of the oven rack.

3 or 4 pans

Place in opposite corners on each oven rack. Stagger pans so no pan is directly over another.

Using aluminum foil for baking

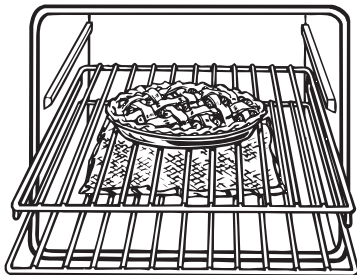

Use aluminum foil to catch spillovers from pies or casseroles:

- **Place** the foil on the oven rack below the rack with the food. **Turn up** foil edges and **make sure** foil is about 1 inch larger all around than the dish holding the food.
- **Do not cover** the entire rack with aluminum foil. It will reduce air circulation and cause poor cooking results.
- **Do not line** oven bottom with foil or other liners. It could affect the quality of your baking.

The electronic oven control

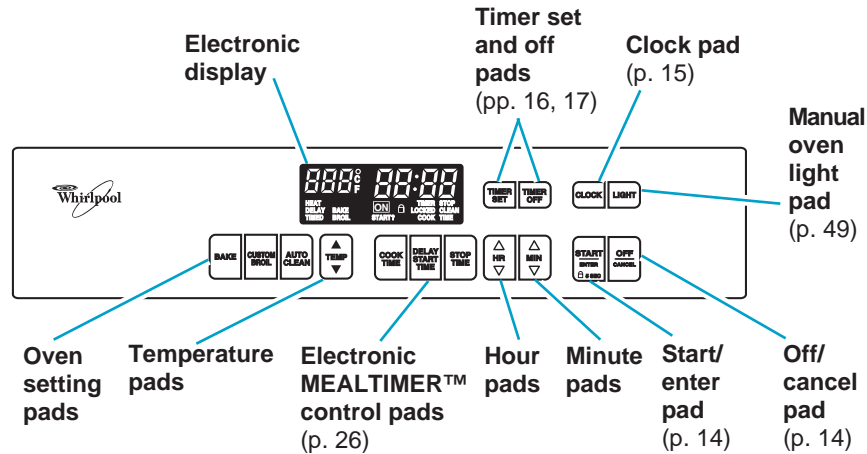

Display/clock

- **When you first plug in the oven**, everything on the display will light up for a few seconds, then a time of day and “PF” will appear on the temperature display. If after you set the clock (see “Setting the clock”), “PF” again appears on the display, your electricity was off for a while. Reset the clock.
- **The clock displays** the time of day, except when the oven is preheating, cleaning, timed baking, and when the display is disabled (see “Disabling the clock display” in the “Setting the clock” section).
- **When you are using the oven or Minute Timer**, the display will show times, temperature settings, and what command pads have been pressed.
- **When showing the time of day**, the display will show the hour and minutes.

- **When you are using the Minute Timer**, the display will show hours, minutes, and seconds in the following sequence:
 - **For settings from 1-59 minutes**, the display will count down each second (minutes and seconds displayed).
 - **For settings 1 hour or over**, the display will count down each minute (hours and minutes displayed).



- **When you are using Cook Time and/or Stop Time**, the display will show cooking time counting down.
 - **For settings from 1-59 minutes**, the display will count down each second (minutes and seconds displayed).
 - **For settings 1 hour or over**, the display will count down each minute (hours and minutes displayed).

USING YOUR RANGE

Command pads

The command pads tell the oven what to do and in what order. Some command pads have an Indicator Light. The Indicator Light comes on when you press the command pad. The ON Indicator Light comes on when you press the Start/Enter pad for an oven function.

Using the control lock

The control lock prevents unwanted use of the oven by disabling most of the control panel command pads (except CLOCK and TIMER SET/OFF).

NOTES:

- **Control lock** is only available when oven is not in use or control has not been set.
- **Set control lock** when cleaning the control panel to prevent oven from accidentally turning on.

To lock or deactivate the control panel:

Press and hold the Start/Enter pad for 5 seconds. A single tone will sound and “Loc” and  will appear on the temperature display. When the control is locked, “START?” will appear on the display if you press any command pad.



To unlock the control panel:

Press and hold the Start/Enter pad for 5 seconds. A single tone will sound and “Loc” and  will disappear from the temperature display.



Starting a function

After programming a function, you must press the Start/Enter pad to start the function. If you do not press the Start/Enter pad within 5 seconds of programming, “START?” will show on the display as a reminder. The control will return to time of day mode after 5 minutes if Start/Enter is not pressed.



Canceling a function

The Off/Cancel pad will cancel any function except for the Clock and Timer Set functions. When you press the Off/Cancel pad, the display will show the time of day or, if Minute Timer is also being used, the time remaining. To cancel the Minute Timer see “Using the electronic Minute Timer” section.



NOTE: You may hear a fan blowing in the oven even after you press the Off/Cancel pad. This is the cooling fan. It will turn off when the oven cools down.

Setting the clock

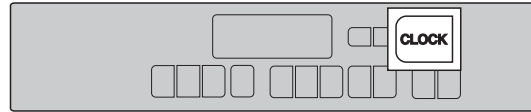

1. Press Clock pad.

PRESS



YOU SEE



(last time of day remembered)

2. Set time.

Press the “up” (▲) or “down” (▼) pad(s) until the correct time shows on the display.

PRESS



YOU SEE



(example for 5:30)

3. Start clock.

PRESS



YOU SEE



Disabling the clock display:

If you do not want the clock time displayed, press and hold the Clock pad for 5 seconds. To display the clock time again, press and hold the Clock pad for 5 seconds. You should not have to reset the time.

Using the electronic Minute Timer

The Minute Timer does not start or stop the oven. It works like a kitchen timer. It can be set in hours and minutes up to 12 hours 59 minutes. The Minute Timer will display minutes and seconds for settings under 1 hour. You will hear four 1-second tones when the set time is up unless reminder tones are disabled (see “Disabling the timer reminder tones.”)

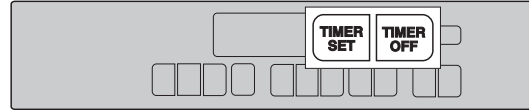

1. Press Timer Set pad.

PRESS



YOU SEE



2. Set time.

Press the “up” (▲) or “down” (▼) pad(s) until the correct time shows on the display.

PRESS



YOU SEE



(example for 10 minutes)

3. Start Minute Timer.

The Minute Timer will begin counting down immediately after the timer is started.

PRESS



YOU SEE



(display counts down)

When the time is up:

You will hear four 1-second tones, then four 1-second **reminder tones** every minute until you press the Timer Off pad.

YOU SEE



4. Turn off Minute Timer.

PRESS



YOU SEE



(time of day)

To cancel the Minute Timer:

Press Timer Off pad.

PRESS



YOU SEE



(time of day)

Disabling the timer reminder tones:

NOTE: To disable the **reminder tones**, press and hold the Timer Set pad for 5 seconds. To enable the tones, follow the same step. After disabling or enabling **reminder tones**, a single tone will sound and the display will return to the Minute Timer countdown or the time of day display.

Audible signals

Audible signals tell you if a function is entered correctly or not. They also tell you when a cycle is completed.

To shut off all signals except for error tones and the hidden function signal:

Press and hold the Stop Time pad for 5 seconds. A short tone will sound to tell you the signals have been changed. Repeat the above step to turn the signals back on.



To choose between high and low volume signals:

Press and hold the Delay Start Time pad for 5 seconds. A short tone will sound to tell you the signals have been changed. "HI" or "LO" will appear on the time display to show the volume you chose. If the volume is changed while the audible signals are off, when signals are turned back on they will be at the volume setting chosen.



USING YOUR RANGE

Baking/roasting

NOTE: See “Roasting tips” later in this section.

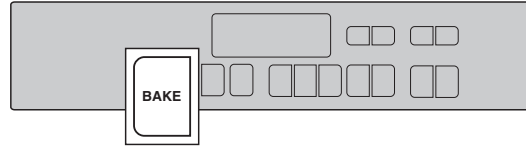

1. Position racks.

For more information, see “Positioning racks and pans.”

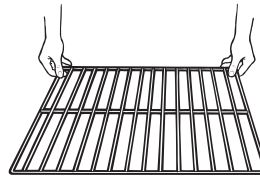

2. Choose baking/roasting setting.

PRESS



YOU SEE



(or 177°C)

3. Set temperature (optional).

Do this step if you want to set a temperature other than 350°F. Press ▲ to raise the temperature or ▼ to lower the temperature in 5°F amounts. Use these pads until the desired temperature shows on the small display. (If the Temp pads are held down, the temperature will change faster.)

PRESS



YOU SEE



(example shows Bake at 375°F)

4. When roasting or cooking casseroles, put food in oven.

You do not have to preheat the oven when roasting or cooking casseroles, unless your recipe recommends it.

NOTE: To set your oven to cook in Celsius instead of Fahrenheit, press and hold the Custom Broil pad for 5 seconds. See “To display temperatures in °C instead of °F” in the “Adjusting the oven temperature control” section.

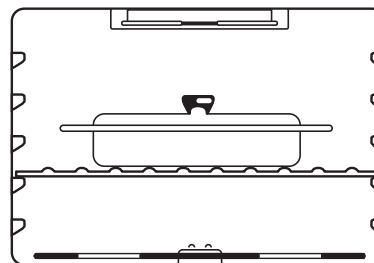

5. Press the Start/Enter pad.

A preheat time will count down on the display. The oven control automatically sets preheat times depending on the oven temperature you select.

TEMPERATURE (in °F)	PREHEAT TIME (in min and sec)
0-325	5 min 45 sec
330-375	7 min 30 sec
380-500	11 min

As the countdown ends, the set temperature replaces "PrE" on the display. You will also hear a 1-second tone.

NOTES:

- **You can change** the temperature setting any time after pressing the Start/Enter pad.
- **The display** will show "door" and the heating elements will not heat if the door is open when you try to bake/roast.

PRESS



YOU SEE



YOU SEE



(display shows set temperature after preheat)

6. When baking, put food in oven after oven is preheated.

During baking/roasting, the elements will turn on and off to keep the oven temperature at the setting.

NOTE: The top element helps heat during baking/roasting, but does not turn red.

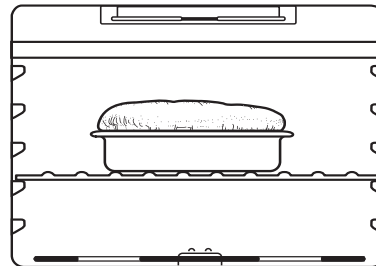

7. After cooking, turn off oven.

PRESS



YOU SEE



(time of day)

USING YOUR RANGE

Roasting tips

- **For even cooking**, place the meat on a rack in a shallow pan. This keeps the meat out of the drippings and allows the heat to circulate better.
- **Use a meat thermometer** for the most accurate doneness. Insert it so the tip is in the center of the largest muscle or thickest portion of the meat or poultry. Make sure the thermometer is not touching bone, fat, or the bottom of the pan.

Adjusting the oven temperature control

Although your new oven is properly adjusted to provide accurate temperatures, it may cook faster or slower than your old oven. If, after using the oven for a period of time, you are not satisfied with the baking/roasting results, you can change the offset temperature by following the steps below:

NOTE: DO NOT measure oven temperature with a thermometer. Opening the oven door will lower the oven temperature and give you an inaccurate reading. Also, the thermometer temperature reading will change as your oven cycles.

1. Press and hold Bake pad for 5 seconds.

The display will show the current offset temperature, for example “0,” if you have not previously adjusted the temperature.

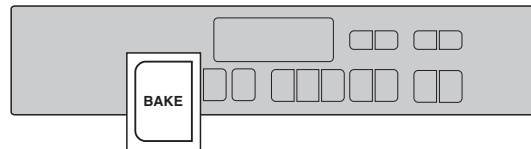

PRESS



YOU SEE



(factory setting of “0”)

2. Set new offset temperature.

Press ▲ to raise the temperature or ▼ to lower the temperature in 10°F amounts. You can set the temperature change to as low as -30°F or as high as +30°F. A minus (-) sign will appear before the number when decreasing the temperature setting to show the oven will be cooler by the displayed amount. There is no sign in front of the number when increasing the temperature setting.

PRESS



YOU SEE



(example when making oven 10°F [or 5°C] hotter)

3. Enter the adjustment.

PRESS



YOU SEE



(time of day)

How to determine the amount of adjustment needed:

The chart at the right tells you how much to adjust the offset temperature to get the desired cooking results. You can determine cooking results by the amount of browning, moistness, and rising times for baked foods.

TO COOK FOOD...	ADJUST BY THIS NUMBER OF DEGREES
A little more	+10°F / +6°C
Moderately more	+20°F / +12°C
Much more	+30°F / +16°C
A little less	-10° F / -6°C
Moderately less	-20° F / -12°C
Much less	-30° F / -16°C

To display temperatures in °C instead of °F:

Press and hold the Custom Broil pad for 5 seconds. A short tone will sound and the temperatures will be displayed in °C. To switch back to °F, repeat the instructions above.



NOTE: The temperature display will not be shown when switching from °F to °C and back. The correct temperature display will appear the next time you press a cook function command pad.

USING YOUR RANGE

Broiling

NOTES:

- **Preheating is not necessary** when broiling, unless your recipe recommends it.
- See “**Broiling tips**” later in this section.

1. Position rack.

NOTE: See the “Broiling rack position chart” for rack placement positions.

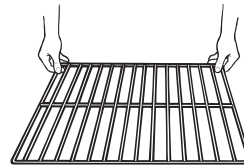
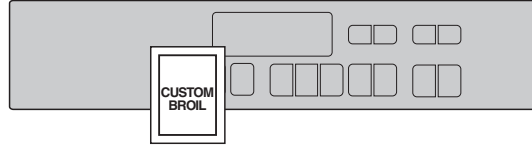

2. Put food on broiler pan and place in center of oven rack.

3. Close door.

NOTE: Do not keep the door open as on other electric ovens. Unlike other electric ovens, the broil element will stay on only with the door closed. This gives you the high heat you need for broiling. However, if you leave the door open, the broil element will go off.

4. Press Custom Broil pad.

PRESS



YOU SEE



(or 260°C)

5. Start oven.

NOTE: You can change the temperature setting any time after pressing the Start/Enter pad. To change the setting, see “To custom broil at a lower temperature” in this section.

PRESS



YOU SEE



6. When broiling is done, turn off oven.

PRESS



YOU SEE

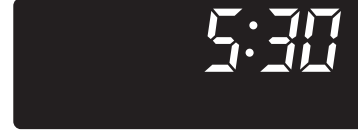

(time of day)

To custom broil at a lower temperature:

- If food is cooking too fast, press the Custom Broil pad and press the ▼ Temp pad until “325°F” shows on the small display.

NOTE: If the Temp pads are held down the temperature will change faster.

PRESS



YOU SEE



(example shows Broil at 325°F)



- If you want food to broil slower from the start, press the Custom Broil pad and press the ▼ Temp pad so a temperature between 170°F and 500°F (75°C and 260°C) shows on the small display.

Lower temperature settings allow for more frequent broil heating element cycling and slower cooking. The lower the temperature, the slower the cooking.

NOTE: Fish and chicken are some foods that may cook better if you use lower broiling temperatures.

PRESS



YOU SEE



(example shows Broil at 400°F)



USING YOUR RANGE

Broiling rack position chart

RACK POSITION FROM BOTTOM	TYPE OF FOOD/ DONENESS
4	Quickly searing food, hamburger patties and thin steaks, 1/2" thick or less, rare steaks
3	Medium steaks, medium patties, ham slices, fish steaks, frankfurters, well-done steaks and patties, lamb chops, split chicken, pork steaks and chops, whole fish

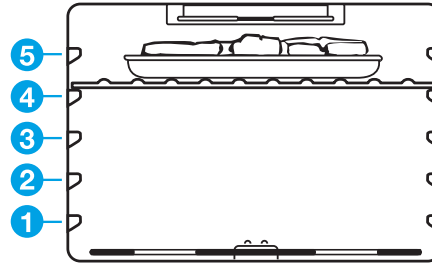

Custom broil chart

The recommended rack position is numbered lowest (1) to highest (5). For best results, as a general rule, turn meat over after approximately $\frac{2}{3}$ of the broiling time. Turn chicken pieces over after approximately $\frac{1}{2}$ of the broiling time. Thinner cuts, such as fish fillets, may not need to be turned. Broil with the door closed.

MEAT	RACK POSITION	TEMPERATURE	APPROXIMATE TIME (MINUTES)
Steak, 1" thick <ul style="list-style-type: none"> • medium-rare • medium • well-done 	4	500°F	19 to 21 minutes 21 to 25 minutes 23 to 28 minutes
Hamburger patties, 3/4" thick <ul style="list-style-type: none"> • well-done 	4	500°F	18 to 20 minutes
Fish, 1/2 to 3/4" thick fillets or steaks	4	500°F	11 to 14 minutes
Pork chops, 1" thick	4	500°F	26 to 28 minutes
Frankfurters	4	500°F	7 to 9 minutes
Chicken pieces, with bones	4	500°F	27 to 31 minutes
Lamb chops, 1" thick	4	500°F	21 to 23 minutes
Ham slice, precooked, 1/2" thick	4	500°F	8 to 10 minutes

Temperatures and times are guidelines only and may need to be adjusted to individual tastes.

Broiling tips

- **Use** the broiler pan and grid for broiling. They are designed to drain extra liquid and grease away from the cooking surface. This drainage helps prevent spatter, smoke, or fire.
- **Do not cover** the broiler grid with foil.
- **To make sure grease drains well**, do not use cookie sheets or similar pans for broiling.
- **Place food** about 3 inches or more from the broil element.
- **After broiling, remove** the broiler pan from the oven when you remove the food. Drippings will bake on the pan if you leave it in the heated oven.

Energy saving tips

Although the energy used for cooking is usually a very small percentage of the total energy used in the home, cooking energy can be used efficiently. Here are some tips to help you save energy when using your cooking product:

Cooktop

- **Match the pan** to the coil element size.
- **The pan** should have a flat bottom, straight sides, and a well-fitting lid.
- **To help shorten your cooking time**, use the least amount of liquid possible.
- **Preheat your pots and pans** only when recommended and for the shortest time possible.
- **Start your food** on a higher heat setting, then turn the control to a lower setting to finish cooking.
- **Place a filled pan** on the coil element before turning it on.

Oven

- **“Oven peeking”** can make cooking times longer and affect the food quality.
- **Rely on a timer** to keep track of cooking time.
- **Plan** your meals for the most efficient use of the oven by cooking more than one food at a time, or baking while the oven is still hot after cooking a meal.
- **It is not necessary to preheat** the oven when broiling or roasting, unless your recipe recommends doing so.

USING YOUR RANGE

Using the electronic MEALTIMER™ control

The electronic MEALTIMER control will turn the oven on and off at times you set, even when you are not around.

Delayed time baking/roasting is ideal for foods which do not require a preheated oven, such as meats and casseroles. **Do not use delayed time cooking for cakes, cookies, etc. – they will not rise properly.**

This section discusses two methods for starting baking/roasting now and stopping automatically later, and three methods for starting and stopping baking/roasting automatically. Read this section carefully to choose which method(s) is best for you.

Before using the electronic MEALTIMER control, make sure the clock is set to the correct time of day. (See the “Setting the clock” section.)

! WARNING

Food Poisoning Hazard

Do not let food sit in oven more than one hour before or after cooking.

Doing so can result in death, food poisoning, or sickness.

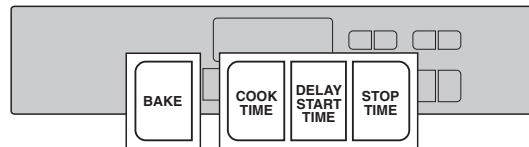

To start baking/roasting now and stop automatically:

Method 1 – Using Cook Time:

1. Prepare oven.

Position the oven rack(s) properly and put food in the oven. For correct rack placement, see “Positioning racks and pans.”

2. Choose Bake setting.

PRESS



YOU SEE



3. Set temperature (optional).

Do this step if you want to set a temperature other than 350°F. Press ▲ to raise the temperature or ▼ to lower the temperature in 5°F amounts. Use these pads until the desired temperature shows on the small display. (If the Temp pads are held down the temperature will change faster.)

PRESS



YOU SEE



(example shows Bake at 375°F [or 191°C])

4. Press Cook Time pad.

PRESS



YOU SEE



5. Set cook time.

Press the “up” (▲) or “down” (▼) pad(s) until the correct time shows on the display.

PRESS



YOU SEE



(example shows 30-minute baking/roasting time)

6. Start oven.

NOTES:

- **You can change** the temperature or time settings any time after pressing the Start/Enter pad by repeating Steps 2 through 5.
- **The display** will show “door” and the heating elements will not heat if the door is open when you try to bake/roast.
- **When you press the Start/Enter pad**, the display will count down the baking/roasting time in hours and minutes (if cook time is more than 1 hour) or in minutes and seconds (if cook time is less than 1 hour).

PRESS



YOU SEE



(display counts down cook time)

continued on next page

USING YOUR RANGE

7. When baking/roasting is done:

The oven will turn off automatically and beep 4 times. You will also hear four 1-second tones every minute (unless they have been disabled [see “Disabling the timer reminder tones” in the “Using the electronic Minute Timer” section]) until you press the Off/Cancel pad.

YOU SEE



Disabling the cook time reminder tones

NOTE: To disable reminder tones, press and hold the Cook Time pad for 5 seconds. To reactivate tones repeat this step.

8. Turn off oven.

NOTE: You can do this step any time to cancel the MEALTIMER™ control setting.

PRESS



YOU SEE



(time of day)

Method 2 – Using Stop Time

1. Prepare oven.

Position the oven rack(s) properly and put food in the oven. For correct rack placement, see “Positioning racks and pans.”

2. Choose Bake setting.

PRESS



YOU SEE



3. Set temperature (optional).

Do this step if you want to set a temperature other than 350°F. Press ▲ to raise the temperature or ▼ to lower the temperature in 5°F amounts. Use these pads until the desired temperature shows on the small display. (If the Temp pads are held down the temperature will change faster.)

PRESS



YOU SEE



(example shows Bake at 375°F [or 191°C])

4. Press Stop Time pad.

PRESS



YOU SEE



5. Set stop time.

Press the “up” (▲) or “down” (▼) pad(s) until the correct time shows on the display.

Example at right shows a desired stop time of 2 o'clock. This provides a 2-hour cook time (the difference between the time of day and the stop time).

PRESS



YOU SEE



(example shows 2 o'clock stop time)

6. Start oven.

NOTES:

- **You can change** the temperature or time settings any time after pressing the Start/Enter pad by repeating Steps 2 through 5.
- **The display** will show “door” and the heating elements will not heat if the door is open when you try to bake/roast.
- **When you press the Start/Enter pad,** the display will count down the baking/roasting time in hours and minutes (if cook time is more than 1 hour) or in minutes and seconds (if cook time is less than 1 hour).

PRESS



YOU SEE



continued on next page

USING YOUR RANGE

7. When baking/roasting is done:

The oven will turn off automatically and beep 4 times. You will also hear four 1-second tones every minute (unless they have been disabled [see “Disabling the timer reminder tones” in the “Using the electronic Minute Timer” section]) until you press the Off/Cancel pad.

YOU SEE



8. Turn off oven.

NOTE: You can do this step any time to cancel the MEALTIMER™ control setting.

PRESS



YOU SEE



(time of day)

To delay start and stop automatically:

Method 1 – Using Cook Time and Delay Start Time:

1. Prepare oven.

Position the oven rack(s) properly and put food in the oven. For correct rack placement, see “Positioning racks and pans.”

2. Choose Bake setting.

PRESS



YOU SEE



3. Set temperature (optional).

Do this step if you want to set a temperature other than 350°F. Press ▲ to raise the temperature or ▼ to lower the temperature in 5°F amounts. Use these pads until the desired temperature shows on the small display. (If the Temp pads are held down the temperature will change faster.)

PRESS



YOU SEE



(example shows Bake at 375°F [or 191°C])

4. Press Cook Time pad.

PRESS



YOU SEE



5. Set cook time.

Press the “up” (▲) or “down” (▼) pad(s) until the correct time shows on the display.

PRESS



YOU SEE



(example shows 30-minute baking/roasting time)

6. Press Delay Start Time pad.

PRESS



YOU SEE



7. Set start time.

Press the “up” (▲) or “down” (▼) pad(s) until the correct time shows on the display.

Example at right shows a desired start time of 2 o'clock. The oven will automatically shut off at 2:30 (the set start time plus the set cook time).

PRESS



YOU SEE



(example shows 2 o'clock start time)

8. Complete entry.

NOTES:

- **You can change** the temperature or time settings any time after pressing the Start/Enter pad by repeating Steps 2 through 7.
- **The display** will show “door” and the heating elements will not heat if the door is open when you try to bake/roast.

PRESS



YOU SEE



continued on next page

USING YOUR RANGE

9. When start time is reached:

A 1-second tone will sound. The display will count down the baking/roasting time in hours and minutes (if cook time is more than 1 hour) or in minutes and seconds (if cook time is less than 1 hour).

YOU SEE



(display counts down cook time)

10. When baking/roasting is done:

The oven will turn off automatically and beep 4 times. You will also hear four 1-second tones every minute (unless they have been disabled [see "Disabling the timer reminder tones" in the "Using the electronic Minute Timer" section]) until you press the Off/Cancel pad.

YOU SEE



11. Turn off oven.

NOTE: You can do this step any time to cancel the MEALTIMER™ control setting.

PRESS



YOU SEE



(time of day)

Method 2 – Using Delay Start Time and Stop Time:

1. Prepare oven.

Position the oven rack(s) properly and put food in the oven. For correct rack placement, see "Positioning racks and pans."

2. Choose Bake setting.

PRESS



YOU SEE



3. Set temperature (optional).

Do this step if you want to set a temperature other than 350°F. Press ▲ to raise the temperature or ▼ to lower the temperature in 5°F amounts. Use these pads until the desired temperature shows on the small display. (If the Temp pads are held down the temperature will change faster.)

PRESS



YOU SEE



(example shows Bake at 375°F [or 191°C])

4. Press Delay Start Time pad.

PRESS



YOU SEE



5. Set start time.

Press the “up” (▲) or “down” (▼) pad(s) until the correct time shows on the display.

Example at right shows a desired start time of 2 o'clock.

PRESS



YOU SEE



(example shows 2 o'clock start time)

6. Press Stop Time pad.

PRESS



YOU SEE



7. Set stop time.

Press the “up” (▲) or “down” (▼) pad(s) until the correct time shows on the display.

Example at right shows a desired stop time of 2:30. This provides a 30-minute cook time (the difference between the start and stop times).

PRESS



YOU SEE



(example shows 2:30 stop time)

continued on next page

USING YOUR RANGE

8. Complete entry.

NOTES:

- You can change the temperature or time settings any time after pressing the Start/Enter pad by repeating Steps 2 through 7.
- The display will show “door” and the heating elements will not heat if the door is open when you try to bake/roast.

PRESS



YOU SEE



9. When start time is reached:

A 1-second tone will sound. The display will count down the baking/roasting time in hours and minutes (if cook time is more than 1 hour) or in minutes and seconds (if cook time is less than 1 hour).

YOU SEE



(display counts down cook time)

10. When baking/roasting is done:

The oven will turn off automatically and beep 4 times. You will also hear four 1-second tones every minute (unless they have been disabled [see “Disabling the timer reminder tones” in the “Using the electronic Minute Timer” section]) until you press the Off/Cancel pad.

YOU SEE



11. Turn off oven.

NOTE: You can do this step any time to cancel the MEALTIMER™ control setting.

PRESS



YOU SEE



(time of day)

Method 3 – Using Cook Time and Stop Time:

1. Prepare oven.

Position the oven rack(s) properly and put food in the oven. For correct rack placement, see “Positioning racks and pans.”

2. Choose Bake setting.

PRESS



YOU SEE



3. Set temperature (optional).

Do this step if you want to set a temperature other than 350°F. Press ▲ to raise the temperature or ▼ to lower the temperature in 5°F amounts. Use these pads until the desired temperature shows on the small display. (If the Temp pads are held down the temperature will change faster.)

PRESS



YOU SEE



(example shows Bake at 375°F [or 191°C])

4. Press Cook Time pad.

PRESS



YOU SEE



5. Set cook time.

Press the “up” (▲) or “down” (▼) pad(s) until the correct time shows on the display.

PRESS



YOU SEE



(example shows 30-minute baking/roasting time)

6. Press Stop Time pad.

PRESS



YOU SEE



continued on next page

USING YOUR RANGE

7. Set stop time.

Press the “up” (▲) or “down” (▼) pad(s) until the correct time shows on the display.

Example at right shows a desired stop time of 2:30. The oven will automatically start cooking at 2:00 (the set stop time minus the set cook time).

PRESS



YOU SEE



(example shows 2:30 stop time)

8. Complete entry.

NOTES:

- **You can change** the temperature or time settings any time after pressing the Start/Enter pad by repeating Steps 2 through 7.
- **The display** will show “door” and the heating elements will not heat if the door is open when you try to bake/roast.

PRESS



YOU SEE



9. When start time is reached:

A 1-second tone will sound. The display will count down the baking/roasting time in hours and minutes (if cook time is more than 1 hour) or in minutes and seconds (if cook time is less than 1 hour).

YOU SEE



(display counts down cook time)

10. When baking/roasting is done:

The oven will turn off automatically and beep four times. You will also hear four 1-second tones every minute (unless they have been disabled [see “Disabling the timer reminder tones” in the “Using the electronic Minute Timer” section]) until you press the Off/Cancel pad.

YOU SEE



11. Turn off oven.

NOTE: You can do this step any time to cancel the MEALTIMER™ control setting.

PRESS



YOU SEE



(time of day)

The oven vent

Hot air and moisture escape from the oven through a vent. The vent for the oven is above the oven door. This vent is needed for air circulation. **Do not block the vent.** Poor baking/roasting can result.

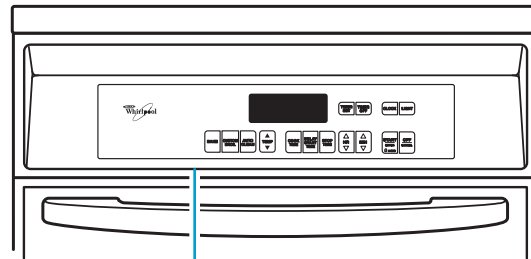

Oven vent

Using the Self-Cleaning Cycle

The Self-Cleaning cycle saves you from the toil and mess that often come with hand-cleaning the oven interior. Like the other functions of your oven, you operate the Self-Cleaning cycle with the easy-to-use controls. Please review the instructions in this section to keep your oven spotless.

	⚠ WARNING
	Burn Hazard Do not touch the oven during the Self-Cleaning cycle. Keep children away from oven during Self-Cleaning cycle. Do not use commercial oven cleaners in your oven. Failure to follow these instructions can result in burns, or illness from inhaling dangerous fumes.

Before you start

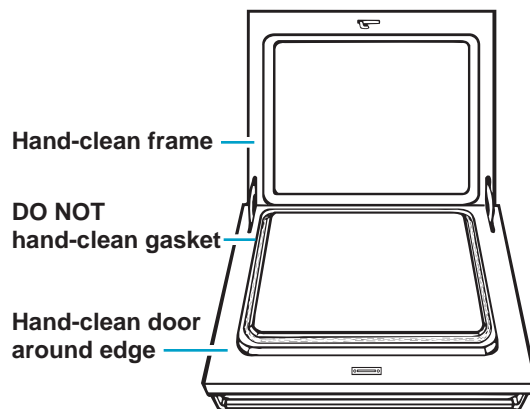

Before you start the Self-Cleaning cycle, make sure you:

- **Hand-clean the areas shown.** They do not get hot enough during the cleaning cycle for soil to burn away. Use hot water and detergent or a soapy steel-wool pad for cleaning.

NOTES:

- **DO NOT** clean, move, or bend the gasket. Poor cleaning, baking, and roasting may result.
- **DO NOT** let water, cleaner, etc., enter slots on door and frame.

- **Remove the broiler pan and grid** and any pots and pans being stored in the oven.
- **Wipe up food spills** containing sugar as soon as possible after the oven cools down. When sugar is heated to a high temperature in the Self-Cleaning cycle, the high temperature can cause the sugar to burn and react with the porcelain. This can cause staining and etching or pitting.
- **Wipe out any loose soil or grease.** This will help reduce smoke during the Self-Cleaning cycle.
- **Remove the oven racks from the oven if you want them to remain shiny.** You can clean the oven racks in the Self-Cleaning cycle, but they will become harder to slide. (See the “Cleaning chart” in the “Caring for Your Range” section.) If you clean racks in the Self-Cleaning cycle, place them on the 2nd and 4th rack guides. (Guides are counted from bottom to top.)
- **Heat and odors** are normal during the Self-Cleaning cycle. Keep the kitchen well ventilated by opening a window or by turning on a vent hood or other kitchen vent during the cycle.

USING THE SELF-CLEANING CYCLE

NOTES:

- **Do not block** the vent during the Self-Cleaning cycle. Air must move freely for best cleaning results.
- **Do not leave** any foil in the oven during the Self-Cleaning cycle. Foil could burn or melt and damage the oven surface.
- **The oven lights** will not work during the Self-Cleaning cycle.
- **Do not leave** plastic utensils on the cooktop. They may melt.

Before setting the controls

- **Make sure clock is set to correct time of day.** (See the “Setting the clock” section.)
- **Make sure the oven door is completely closed.**

Setting the controls

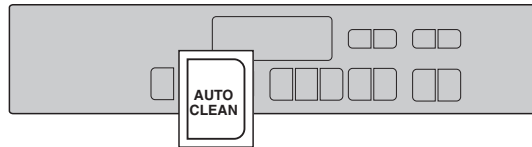

To start cleaning immediately:

1. Press Auto Clean pad.

A 3½-hour Self-Cleaning cycle will be set automatically.

PRESS



YOU SEE



2. Set cleaning time (optional).

If you want a Self-Cleaning cycle longer or shorter than 3½ hours, use the Hour pad to set the desired cleaning time. Press the “up” (▲) or “down” (▼) pad(s) until a time between 2½-4½ hours shows on the display.

- **Use** 2½ hours for light soil.
- **Use** 3½-4½ hours for moderate to heavy soil.

PRESS



YOU SEE



(example for 4½-hour cycle)

continued on next page

USING THE SELF-CLEANING CYCLE

3. Start oven.

PRESS



YOU SEE



4. After Self-Cleaning cycle starts:

LOCKED lights up on the display. The door cannot be opened when LOCKED is on.

YOU SEE



5. After Self-Cleaning cycle ends:

YOU SEE



(example for 5:30 stop time)

YOU SEE



To delay start using delay start time:

1. Press Auto Clean pad.

A 3½-hour Self-Cleaning cycle will be set automatically.

PRESS



YOU SEE



USING THE SELF-CLEANING CYCLE

2. Set cleaning time (optional).

If you want a Self-Cleaning cycle longer or shorter than 3½ hours, use the Hour pad to set the desired cleaning time. Press the “up” (▲) or “down” (▼) pad(s) until a time between 2½-4½ hours shows on the display.

- Use 2½ hours for light soil.
- Use 3½-4½ hours for moderate to heavy soil.

PRESS



YOU SEE



(example for 4½-hour cycle)

3. Press Delay Start Time pad.

PRESS



YOU SEE



4. Set start time.

Press the “up” (▲) or “down” (▼) pad(s) until the correct time shows on the display. The oven will automatically compute the stop time by adding the set cleaning time to the set start time.

PRESS



YOU SEE



(example for 2:30 start time)

5. Complete entry.

The door is locked as soon as you press the Start/Enter pad.

PRESS



YOU SEE



6. After Self-Cleaning cycle starts:

LOCKED lights up on the display. The door cannot be opened when LOCKED is on.

YOU SEE



continued on next page

USING THE SELF-CLEANING CYCLE

7. After Self-Cleaning cycle ends:

NOTES:

- **The stop time** will be the start time plus the cleaning time.
- **The fan** may stay on after the Self-Cleaning cycle ends, until the oven cools down.

YOU SEE



(example for 7:00 stop time)

YOU SEE



To stop the Self-Cleaning cycle at any time:

If the oven temperature is too high for baking/roasting when you press the Off/Cancel pad, "cln," TIMED, ON, "cool," and LOCKED will appear on the display until the oven cools.

PRESS



YOU SEE

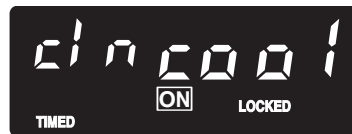

Special tips

- **Keep** the kitchen well ventilated during the Self-Cleaning cycle to help get rid of heat, odors, and smoke.
- **After the oven cools to room temperature**, wipe up any residue or ash with a damp cloth or sponge. If any spots remain, clean with a mild abrasive cleanser or cleaning sponge.
- **Clean** the oven before it gets heavily soiled. Cleaning a very soiled oven takes longer and could cause an increased amount of smoke.
- **If the Self-Cleaning cycle** does not get the oven as clean as you expected, the cycle may not have been set long enough or you may not have prepared the oven properly. Set the Self-Cleaning cycle longer the next time and hand-clean areas noted in “Before you start.”

How the cycle works

The Self-Cleaning cycle uses very high heat to burn away soil and grease. During the cycle, the oven gets much hotter than it does for normal baking or broiling. This high heat breaks up the soil or grease and burns it away.

Your oven is preset for a 3½-hour Self-Cleaning cycle. However, you can adjust the cycle time to the amount of soil in your oven. You can set the cycle anywhere between 2½ and 4½ hours. (See “Setting the controls.”)

The graph at the right is representative of a normal, 3½-hour Self-Cleaning cycle. Note that the heating stops ½ hour before the 3½-hour setting is up to cool the oven enough so the door can be unlocked.

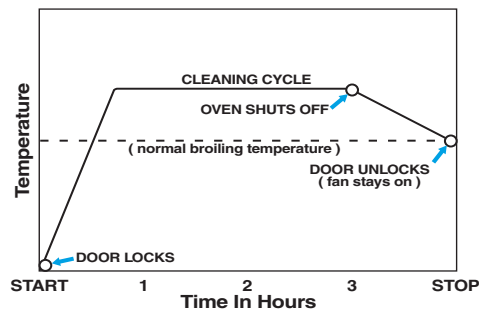

Caring for Your Range

Your range is designed for easy care. You can do most cleaning with items found around your home. Cleaning your range whenever spills or soiling occurs will help to keep it looking and operating like new.

	! WARNING
	<p>Explosion Hazard</p> <p>Do not store flammable materials such as gasoline near this appliance.</p> <p>Doing so can result in death, explosion, or fire.</p>

Cleaning chart

PART	WHAT TO USE	HOW TO CLEAN
Control knobs	Sponge and warm, soapy water	<ul style="list-style-type: none"> • Turn knobs to OFF and pull straight away from control panel. • Wash, rinse, and dry thoroughly. Do not soak. • Do not use steel wool or abrasive cleansers. They may damage the finish of the knobs. • Replace knobs. Make sure all knobs point to OFF.
Control panel	Sponge and warm, soapy water OR Paper towel and spray glass cleaner	<ul style="list-style-type: none"> • Wash, wipe with clean water, and dry thoroughly. • Do not use steel wool or abrasive cleansers. They may damage the finish. • Do not spray cleaner directly on panel. Apply cleaner to paper towel. <p>NOTE: Set the Control Lock to prevent the oven from accidentally turning on when you are cleaning the panel. (See “Using the control lock” in “The electronic oven control” section.)</p>
Coil elements	No cleaning required	<ul style="list-style-type: none"> • Spatters or spills will burn off. • Do not immerse in water.
Chrome reflector bowls	Warm, soapy water and a nonabrasive, plastic scrubbing pad	<ul style="list-style-type: none"> • Wash, rinse, and dry thoroughly. • Clean frequently. • Do not use abrasive or harsh cleansers. • Do not clean in Self-Cleaning cycle.

CARING FOR YOUR RANGE

PART	WHAT TO USE	HOW TO CLEAN
Exterior surfaces (other than control panel)	Sponge and warm, soapy water	<ul style="list-style-type: none"> Wash, wipe with clean water, and dry thoroughly. Use nonabrasive, plastic scrubbing pad on heavily soiled areas. Do not use abrasive or harsh cleansers. They may damage the finish.
Broiler pan and grid (clean after each use)	Steel-wool pad and warm, soapy water	<ul style="list-style-type: none"> Wash, rinse, and dry thoroughly. Do not clean in Self-Cleaning cycle. See “Before you start” in the “Using the Self-Cleaning Cycle” section.
Oven racks	Steel-wool pad and warm, soapy water OR The Self-Cleaning cycle	<ul style="list-style-type: none"> Wash, rinse, and dry thoroughly. <p>OR</p> <ul style="list-style-type: none"> Leave in oven during Self-Cleaning cycle. <p>NOTE: Racks will permanently discolor and become harder to slide if left in oven during Self-Cleaning cycle. Apply a small amount of vegetable oil to the side rungs to aid sliding.</p>
Oven door glass and window	Paper towel and spray glass cleaner OR Warm, soapy water and a nonabrasive, plastic scrubbing pad	<ul style="list-style-type: none"> Make sure oven is cool. Follow directions provided with the cleaner. Wash, wipe with clean water, and dry thoroughly.
Oven cavity	Self-Cleaning cycle	<ul style="list-style-type: none"> Wipe up food spills containing sugar as soon as possible after the oven cools down. See the “Using the Self-Cleaning Cycle” section.

Coil elements and reflector bowls

Removing

1. **Make sure** all coil elements are off and cool before removing the coil elements and reflector bowls.



2. **Lift** the edge of the coil element, opposite the receptacle, just enough to clear the element hold-down clip and the reflector bowl.

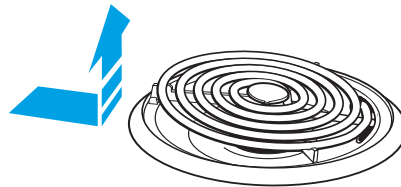

3. **Pull** the coil element straight away from the receptacle.

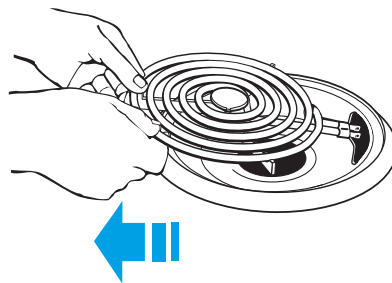

4. **Lift out** the reflector bowl. **See** "Cleaning chart" for cleaning instructions.

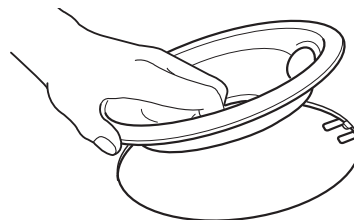

Replacing

1. **Make sure** all coil elements are off and cool before replacing the coil elements and reflector bowls.

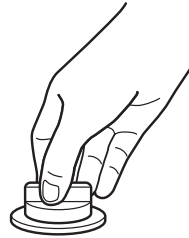

2. **Line up** openings in the reflector bowl with the coil element receptacle and the element hold-down clip.

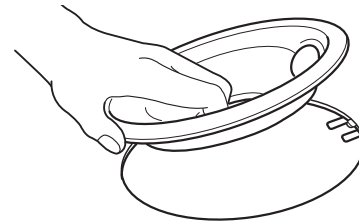

3. **Hold** the coil element as level as possible with the terminal just started into the receptacle. **Push** the coil element terminal into the receptacle.

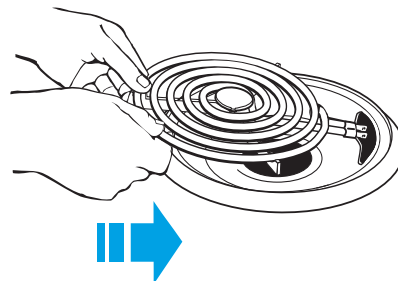

4. When terminal is pushed into the receptacle as far as it will go, **push down** the edge of the coil element opposite the receptacle. The element hold-down clip will keep the coil element from moving around.

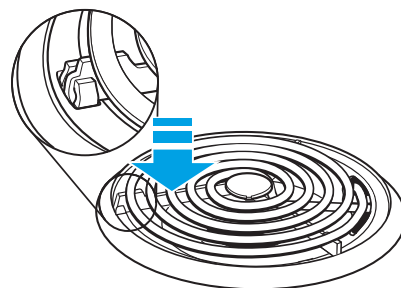

NOTE: Reflector bowls reflect heat back to the cookware on the coil elements. They also help catch spills. When they are kept clean, they reflect heat better and look new longer.

If a reflector bowl gets discolored, some of your cookware may not be flat enough, or some may be too large for the coil element. In either case, some of the heat that's meant to go into or around the cookware goes down and heats the reflector bowl. This extra heat can discolor it.

Removing the oven door

For normal use of your oven, you do not need to remove the door. However, if you have to remove the door follow the instructions in this section.

The oven door is heavy. Use both hands to remove and replace the door. Do not lift and carry the door by the handle. To remove and replace the door you may need help.

To remove:

1. **Open** door all the way.

NOTE: Two $\frac{5}{32}$ " Allen wrenches or 2 nails of similar diameter may be used if factory furnished door removal pins have been misplaced. Be careful not to damage porcelain finish.

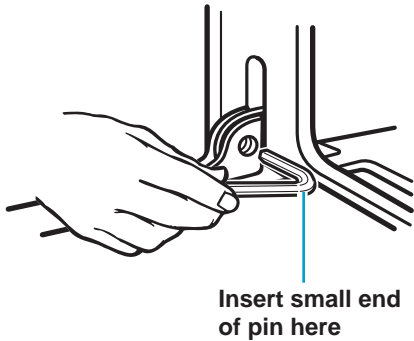

2. **Insert** small end of a door removal pin into each door hinge.

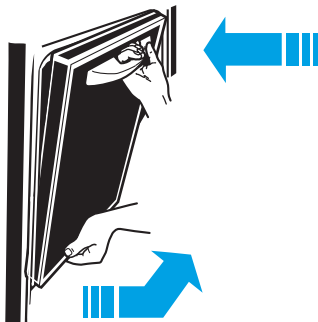

3. **Grasp** under handle and gently close door as far as it will shut. **Pull** door out at bottom to remove.
4. **Set** door aside on protected surface.

To replace:



1. **Fit** hinge arms into slots in frame. **Push in** at lower corners to ensure that hinge arms are fully engaged.
2. **Open** the door all the way.
3. **Remove** the door removal pins from each hole.
4. **Close** the door.

NOTE: If the door does not operate freely, you have not installed it properly. Repeat Steps 1-4.

The oven lights

The oven lights will come on when you open the oven door. To turn the lights on when the oven door is closed, press the Oven Light pad  on the control panel.

To replace an oven light:

1. **Disconnect** power and make sure the oven is cool before replacing the light bulb.

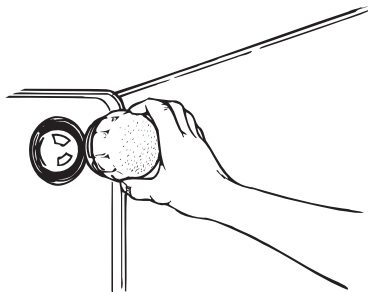

2. **Remove** the glass bulb cover in the back of the oven by turning it counterclockwise.
3. **Remove** the light bulb from its socket. **Replace** the bulb with a similar 125-volt, 15-watt appliance bulb.

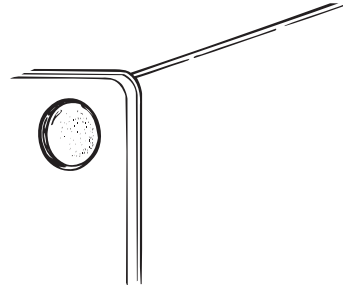

4. **Replace** the light bulb cover by turning it clockwise. The light bulb cover must be in place when using the oven. The cover protects the bulb from breaking and from high oven temperatures.
5. **Reconnect** power.

NOTE: The oven lights will not work during the Self-Cleaning cycle.

Troubleshooting

Most cooking problems often are caused by little things you can find and fix without tools of any kind. Check the lists below and on the next page before calling for assistance or service. If you still need help, see the “Requesting Assistance or Service” section on page 52.

If nothing operates, check the following:

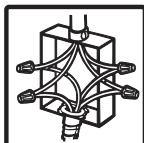

Is the oven wired into a live circuit with the proper voltage?
(See Installation Instructions.)



Have you blown a household fuse or tripped a circuit breaker?

Other possible problems and their causes:

PROBLEM	CAUSE
The oven will not operate	<ul style="list-style-type: none"> You have not set the electronic control correctly. Refer to the section in this manual describing the function you are operating. You have accidentally set the control lock. See the “Using the control lock” section on page 14. You have programmed a delayed start time. Wait for the start time to be reached or cancel and reset the controls.
The coil elements will not operate	<ul style="list-style-type: none"> You have blown a household fuse or tripped a circuit breaker. Replace the fuse or reset the circuit breaker. You have not plugged in coil elements all the way. Turn control knobs to OFF and plug in coil elements all the way. (See “Replacing” on page 47.) You are not setting the control knob correctly. Push the control knob in before turning to a setting.
The control knob(s) will not turn	<ul style="list-style-type: none"> You are not pushing in before turning. Push the control knob(s) in before turning to a setting.
The Self-Cleaning cycle will not operate	<ul style="list-style-type: none"> You did not press the Start/Enter pad. You have programmed a delayed start time. Wait for the start time to be reached or cancel and reset the controls.
Display is blank	<ul style="list-style-type: none"> You have set the display not to show the clock time. To see the clock time again, press and hold the Clock pad for 5 seconds.

TROUBLESHOOTING

PROBLEM	CAUSE
Cooking results are not what you expected	<ul style="list-style-type: none"> • The range is not level. (See Installation Instructions.) • The oven temperature seems too low or too high. See the “Adjusting the oven temperature control” section on page 20 to adjust the oven temperature. • You did not preheat the oven before baking (if called for in recipe). • You are using a pan that is not the correct type or size. Refer to a reliable cookbook or recipe for recommended pan type and size. • There is not enough air space around pan when baking. Allow 1½ to 2 inches of air space on all sides of pan. • The cookware is too large or too small for the coil element being used. The pan should be the same size or slightly larger than the coil element being used.
The display is showing “PF”	<ul style="list-style-type: none"> • There has been a power failure. Reset the clock. (See “Setting the clock” on page 15.)
“F” followed by a number shows on the display	<ul style="list-style-type: none"> • Press the Off/Cancel pad. If the code reappears, note the code and call for service. (See Step 2 in the “Requesting Assistance or Service” section on page 52.)

If none of these items was causing your problem, see the “Requesting Assistance or Service” section on page 52.

Requesting Assistance or Service

Before calling for assistance or service, please check the “Troubleshooting” section. It may save you the cost of a service call. If you still need help, follow the instructions below.

1. If you need assistance* ...

Call Whirlpool Consumer Assistance



Center telephone number.
Dial toll-free from anywhere
in the U.S.A.:

1-800-253-1301

and talk with one of our trained consultants. The consultant can instruct you in how to obtain satisfactory operation from your appliance or, if service is necessary, recommend a qualified service company in your area.

If you prefer, write to:

Whirlpool Brand Home Appliances
Consumer Assistance Center
c/o Correspondence Department
2000 North M-63
Benton Harbor, MI 49022-2692

Please include a daytime phone number in your correspondence.

2. If you need service* ...

Whirlpool has a nationwide network of authorized Whirlpool service companies. Whirlpool service technicians are trained to fulfill the product warranty and provide after-warranty service, anywhere in the United States. To locate the authorized Whirlpool service company in your area, call our Consumer Assistance Center telephone number (see Step 1) or look in your telephone directory Yellow Pages under:

• **APPLIANCE-HOUSEHOLD-MAJOR, SERVICE & REPAIR**

- See: Whirlpool Appliances or Authorized Whirlpool Service
(Example: XYZ Service Co.)

• **WASHING MACHINES & DRYERS, SERVICE & REPAIR**

- See: Whirlpool Appliances or Authorized Whirlpool Service
(Example: XYZ Service Co.)



3. If you need FSP® replacement parts ...

FSP is a registered trademark of Whirlpool Corporation for quality parts. Look for this symbol of quality whenever you need a replacement part for your WHIRLPOOL® appliance. FSP replacement parts will fit right and work right, because they are made to the same exacting specifications used to build every new WHIRLPOOL appliance.

To locate FSP replacement parts in your area, refer to Step 2 or call the Whirlpool Consumer Assistance Center number in Step 1.

4. If you are not satisfied with how the problem was solved ...

- Contact the Major Appliance Consumer Action Program (MACAP). MACAP is a group of independent consumer experts that voices consumer views at the highest levels of the major appliance industry.
- Contact MACAP only when the dealer, authorized servicer, and Whirlpool have failed to resolve your problem.

Major Appliance Consumer
Action Program
20 North Wacker Drive
Chicago, IL 60606

- MACAP will in turn inform us of your action.

* When asking for help or service:

Please provide a detailed description of the problem, your appliance's complete model and serial numbers, and the purchase date. (See the “A Note to You” section.) This information will help us respond properly to your request.

Index

This index is alphabetical. It contains all the topics included in this manual, along with the page(s) on which you can find each topic.

<u>TOPIC</u>	<u>PAGE</u>	<u>TOPIC</u>	<u>PAGE</u>
AIR CIRCULATION	12	CONTROL PANELS	
ASSISTANCE	52	Canceling	14
BAKING		Celsius/Fahrenheit	21
Aluminum foil	12	Clock	15
Pans	11	Coil element markers	9
Setting cycle	18	Command pads	14
BROILING		Control knobs	9
Custom broil chart	24	Control lock	14
Grid	25	Disabling the clock display	15
Pan	25	Display	13
Rack position chart	24	Hot surface indicator light	9
Setting cycle	23	Hour and minute pads	13
Tips	25	Minute timer	16
CLEANING		Signals	17
Broiler pan and grid	45	Starting	14
Coil elements	44	Tones	17
Control knobs	44	COOKWARE	
Control panel	44	Canning	10
Exterior surfaces	45	Tips	10
Oven cavity	45	ENERGY SAVING TIPS	25
Oven door glass	45	FEATURES	8
Oven racks	45	LIGHTS	49
Reflector bowls	44	LOCK	
Self-cleaning cycle	38	Control	14
COIL ELEMENTS		Self-cleaning cycle	40, 41
Coil element markers	9	MODEL AND SERIAL NUMBER	3
Control knobs	9	OVEN TEMPERATURE	
Control setting guide	9	Adjusting	20
Hot surface indicator light	9	Setting	18, 23, 27, 29, 30, 33, 35
Tips	10	OVEN VENT	37

TOPIC	PAGE	TOPIC	PAGE
PANS	11	SERVICE	52
PARTS	8	TIMED COOKING	
RACKS	11	Canceling	28, 30, 32, 34, 37
REMOVING THE OVEN DOOR	48	Cook time	27, 31, 35
ROASTING		Delay start time	30, 32
Aluminum foil	12	Stop time	29, 33, 35
Pans	11	TIPS	
Setting cycle	18	Bakeware	11
SAFETY	4-7	Broiling	25
SELF-CLEANING		Cookware	10
Delay cleaning	40	Saving energy	25
How cycle works	43	Self-cleaning	43
Preparing oven	38, 39	TROUBLESHOOTING	50-51
Setting controls	39	WARRANTY	56
Starting immediately	39		
Stopping cycle	42		
Tips	43		

WHIRLPOOL®

Electric Range Warranty

LENGTH OF WARRANTY	WHIRLPOOL WILL PAY FOR
FULL ONE-YEAR WARRANTY FROM DATE OF PURCHASE	FSP® replacement parts and repair labor to correct defects in materials or workmanship. Service must be provided by an authorized Whirlpool service company.
WHIRLPOOL WILL NOT PAY FOR	
<p>A. Service calls to:</p> <ol style="list-style-type: none"> 1. Correct the installation of your range. 2. Instruct you how to use your range. 3. Replace house fuses or correct house wiring. 4. Replace owner-accessible light bulbs. <p>B. Repairs when your range is used in other than normal, single-family household use.</p> <p>C. Pickup and delivery. Your range is designed to be repaired in the home.</p> <p>D. Damage to your range caused by accident, misuse, fire, flood, acts of God, or use of products not approved by Whirlpool.</p> <p>E. Repairs to parts or systems caused by unauthorized modifications made to the appliance.</p>	

1/97

WHIRLPOOL CORPORATION SHALL NOT BE LIABLE FOR INCIDENTAL OR CONSEQUENTIAL DAMAGES. Some states do not allow the exclusion or limitation of incidental or consequential damages, so this exclusion or limitation may not apply to you. This warranty gives you specific legal rights, and you may also have other rights which vary from state to state.

Outside the United States, a different warranty may apply. For details, please contact your authorized Whirlpool dealer.

If you need service, first see the “Troubleshooting” section of this book. After checking “Troubleshooting,” additional help can be found by checking the “Requesting Assistance or Service” section or by calling our Consumer Assistance Center telephone number, **1-800-253-1301**, from anywhere in the U.S.A.